

# MICHAËL CAMELLINI

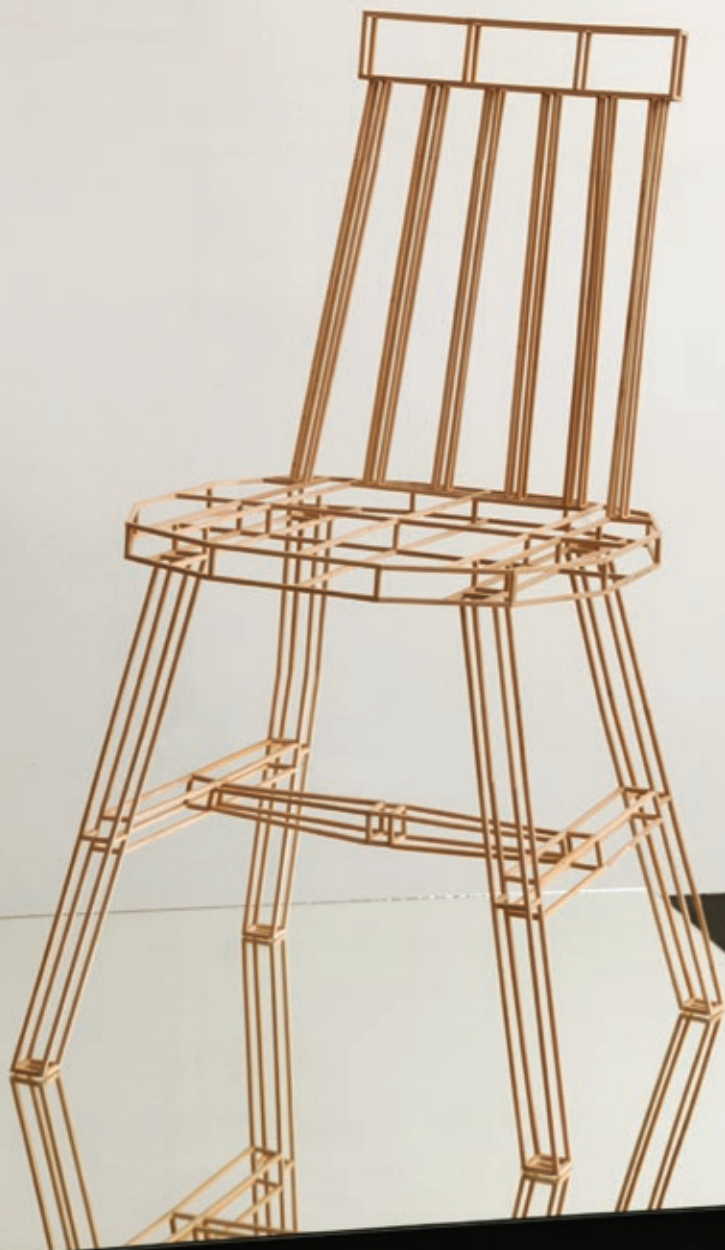

**MICHAËL CAMELLINI**

SCULPTURES

MISCARE

série de sculptures en bois de cade  
*series of sculptures of cedar wood*  
2013



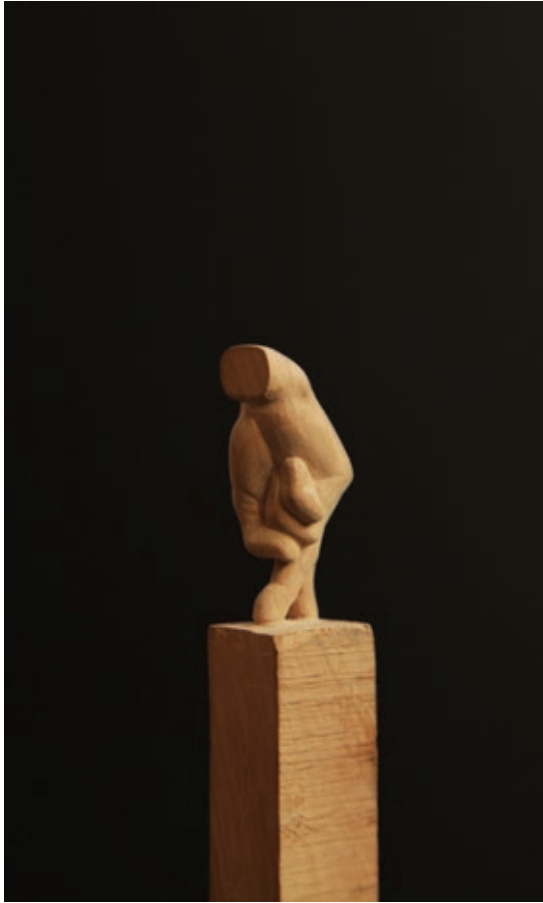

MAIN (MISCARE)

bois de cade cedar wood  
15 / 2,5o / 2,5o cm  
2o13





INTÉRUPTEUR (MISCARE)

bois de cade cedar wood  
12 / 2,5o / 2,5o cm  
2o13





FUSÉE (MISCARE)

bois de cade cedar wood  
18 / 2,50 / 2,50 cm  
2013





CHAISE (MISCARE)

bois de cade cedar wood  
16 / 2,50 / 2,50 cm  
2013

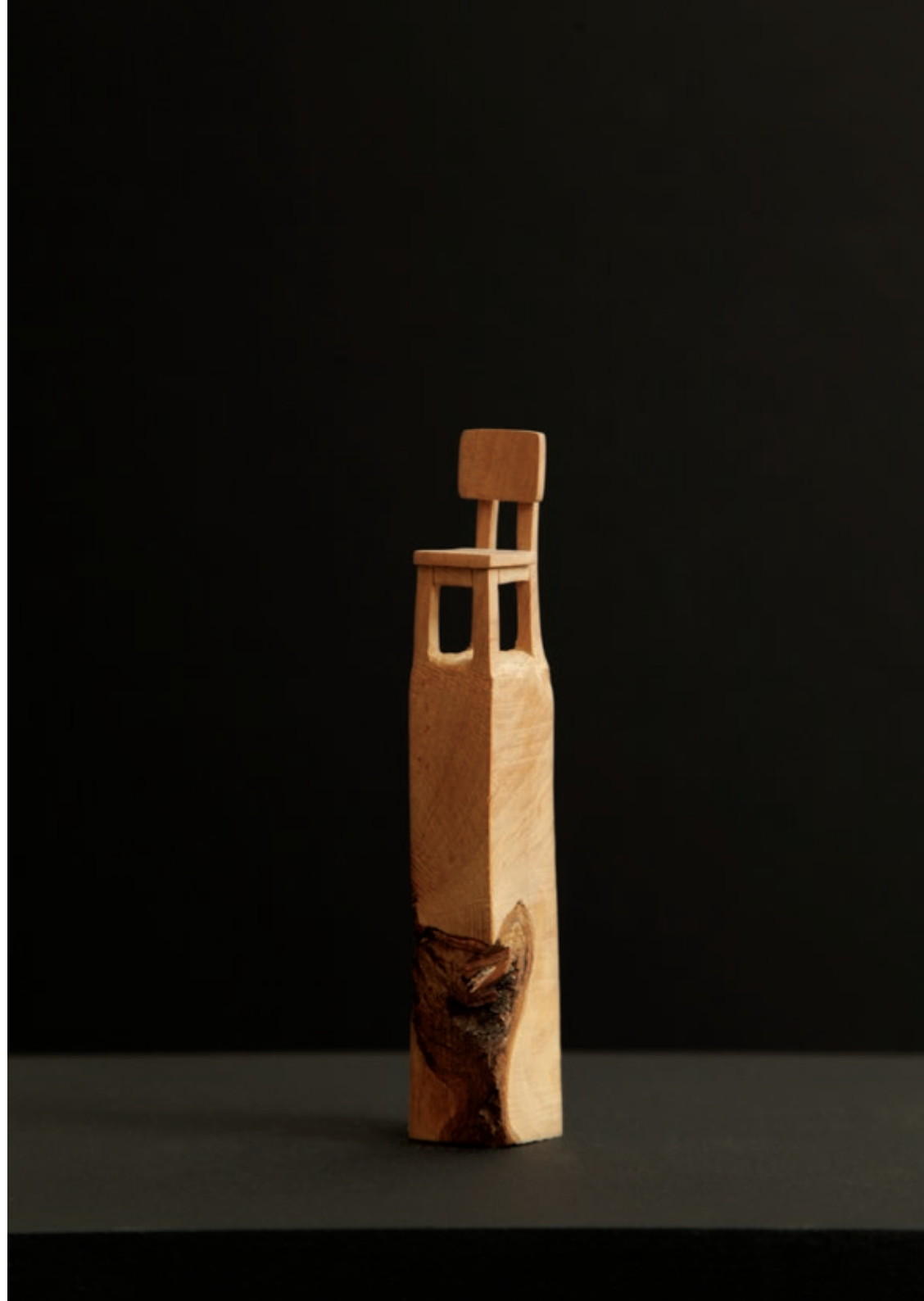



ESCARPIN (MISCARE)

bois de cade cedar wood  
20 / 2,50 / 2,50 cm  
2013





SUPPOSITOIRE

marbre *marble*  
2 / 7,5o / 9,5o cm  
2o14



ARCHITECTURES UTOPIQUES

série de sculptures en béton  
*series of concrete sculptures*  
2014



ARCHITECTURES UTOPIQUES o1

cuivre, béton, ivoire de mamouth  
*copper, concrete, mammoth ivory*  
15 / 15 / 7cm  
2014





ARCHITECTURES UTOPIQUES 02

cuir, bois, béton, ivoire de mamouth  
*leather, wood, concrete, mammoth ivory*  
15 / 15 / 45cm  
2014

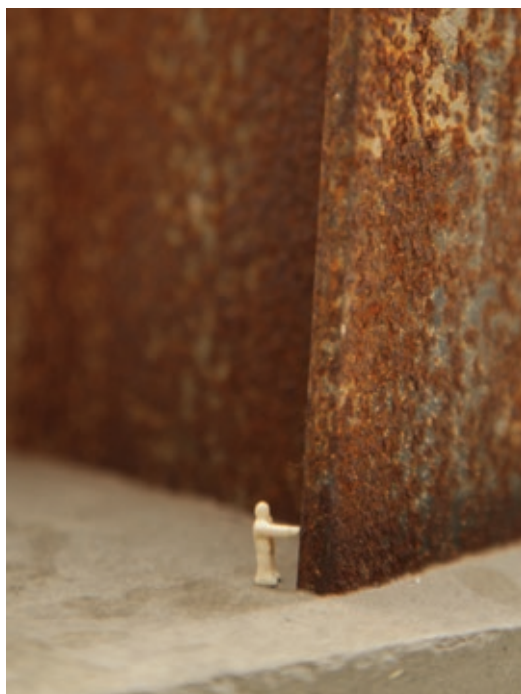

ARCHITECTURES UTOPIQUES 03

acier, béton, ivoire de mamouth  
steel, wood, concrete, mammoth ivory  
15 / 15 / 15cm  
2014

OSSATURE

résine  
50 / 50 / 50 cm  
Time out, Nike x Pigalle, Paris  
2014



## ÉQUILIBRES

série de sculptures  
*series of sculptures*  
2016



BLOCS o3

bois de pin *pine wood*  
45 / 14 / 14 cm  
2014





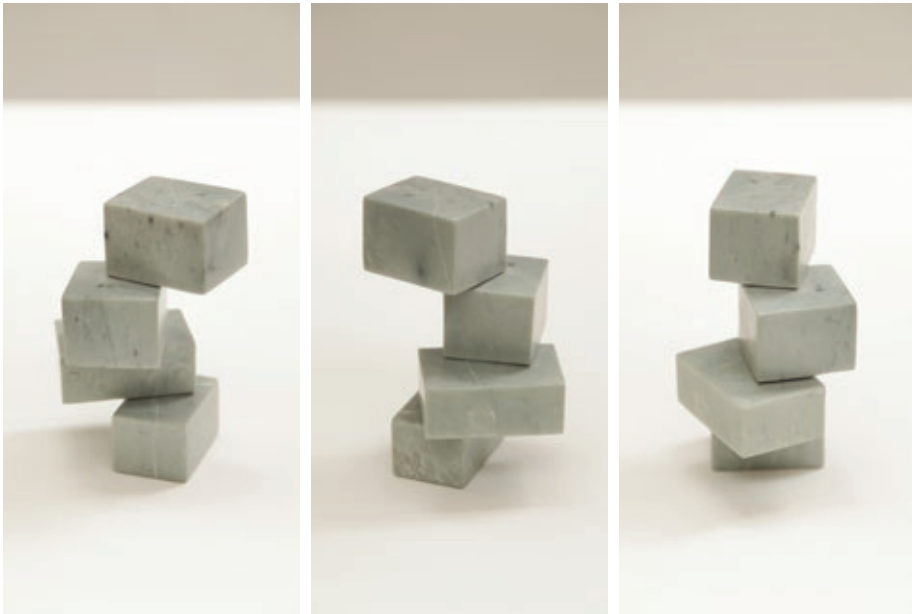

BLOCS o2

stéatite *steatite*  
14 / 9 / 9cm  
2014

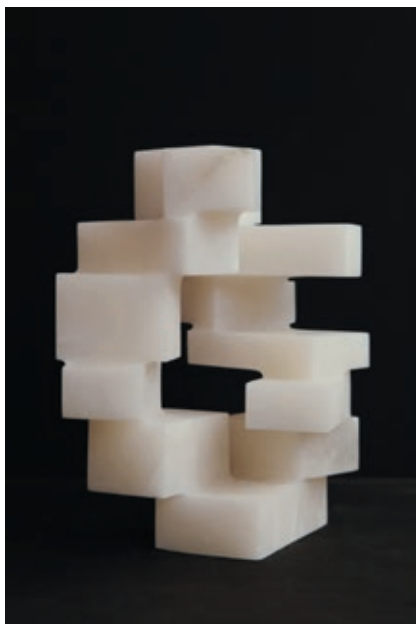

BLOCS o4

albâtre *alabaster*  
27 / 22 / 20cm  
2016





CUBE o1

bois de pin *pine wood*  
27 / 22 / 20cm  
2016

CUBE o2

bois de pin *pine wood*  
39 / 33 / 23 cm  
2016



LÉGERE COMME UNE PIERRE

bois, calcaire de moselle wood, lime  
33 / 6,80 / 6,80cm  
2016



PRIMARY MOVEMENT

série de sculptures *series of sculptures*  
bois, tissu, corde *wood, fabric, rope*  
50 / 55 / 24 cm  
2016















PRIMARY MOVEMENT

adulte et petit *adult and child*  
bois, tissu, corde *wood, fabrique, rope*  
50 / 55 / 24 cm  
2016





## PRIMARY MOVEMENT

bois, tissu, corde wood, fabrique, rope  
groupe de sculptures group of sculptures  
sculpture 2 / 2 / 0,50 m / installation 2 / 12 / 6 m  
Palais de Tokyo, Paris  
2016

## L'IMPOSSIBLE REPOS

bâtonnets de «barbe à papa» en bois de pin  
"cotton candy" sticks made of pine wood  
83 / 46 / 43 cm  
2017

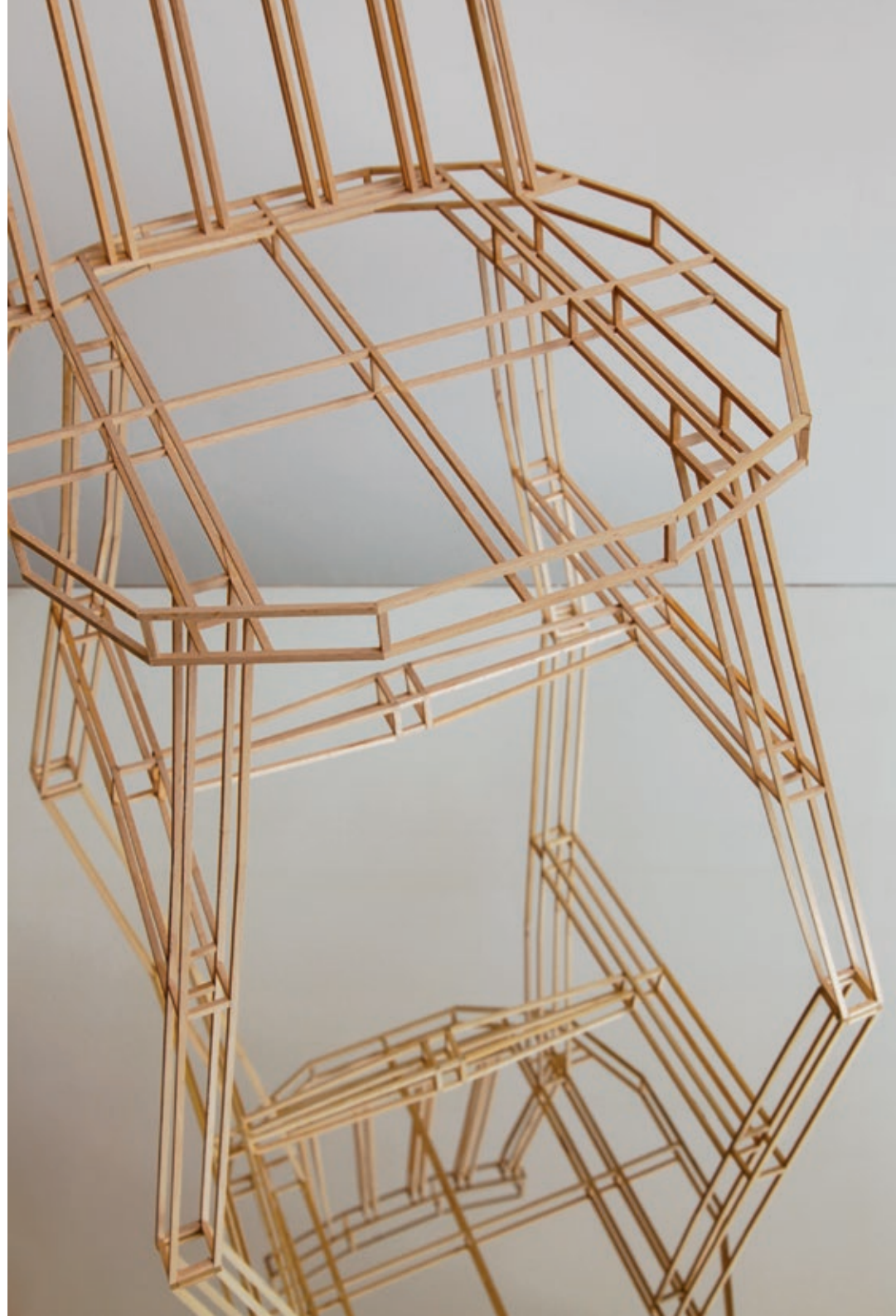



UMN'S NOT DEAD

plâtre peint, machine à laver miniature  
*plaster, mini washing machine*  
40 / 20 / 20cm  
2016





## BIOGRAPHIE BIOGRAPHY

Michaël Camellini (1971) a grandi et fait ses études d'arts à Paris (ESAG, Université de Paris VIII). Après avoir assisté les artistes Gilles de Kerverseau et Pira, il devient sculpteur. Son intérêt pour les formes, le dessin, les techniques et les matières l'ont amené à explorer des métiers d'art tel que la joaillerie, aussi bien que les technologies du digital. Michaël Camellini habite et travaille à Vitry-sur-Seine, France.

*Michaël Camellini was born in Paris in 1971. He studies Fine Arts and Art History in Paris at the Met de Penninghen art school and at the University of Paris VIII. After being an assistant of several artists, he became a sculptor. His interests about materials and technics pushed him to be also a jeweller and a digital designer.*

*Michaël Camellini is living in Vitry-sur-Seine, Île-de-France, France.*

## EXPOSITIONS EXHIBITIONS

2011

Nuits Blanches / Mairie du Xle / Paris, France  
Galerie Art top / Aix en Provinces, France  
Contemporary Art Ruhr / Essen, Allemagne

2012

Contemporary Art Ruhr / Essen, Allemagne  
Collection Buquet / exposition personnelle / Lille, France

2013

Cinema de la nouvelle lune / Cité Internationale des Arts / Paris, France  
Une nouvelle unité / Marseille, Capitale européenne de la culture / Marseille, France

2014

Time out / Paris, France  
Parklandschaften / Weimar, Allemagne  
Minimenta / galerie Point Rouge / Paris, France

2015

Cabane Georgina #02 / Marseille, France  
Das Glücksprinzip / Weimar, Allemagne  
Curiosity / Untitled Factory / Paris, France

2016

Palais des monteurs / Palais de Tokyo / Paris, France  
Jubiläumsausstellung – 10 Jahre Galerie Eigenheim / Berlin, Allemagne  
La métis du renard et du poulpe / Cabane Gerogina #03 / Marseille, France  
Sights of Evolution / Bagnolet, Île-de-France, France

2017

Jubiläumsausstellung – 10 Jahre Galerie Eigenheim / Weimar, Allemagne  
La convergence des lignes / Galerie Détails / Paris, France

## CONTACT CONTACT

Michaël Camellini  
umn.project@gmail.com  
fb : michael camellini  
tel : 0033 (0) 676 495170

OURS *IMPRINT*

MICHAËL CAMELLINI

Michaël Camellini / Sculptures  
Werkskatalog #11  
September 2017

ISSN 1864-9882

1. ÉDITION *EDITION*

50

EDITEUR *PUBLISHER*

Journal of Culture  
Kirschbergstraße 72, 04155 Leipzig  
Allemagne

DESIGN *DESIGN*

PHOTOGRAPHIE *PHOTOGRAPHY*  
Julia Scorna  
Photo of Ossature Pigalle, Paris

CONTACT *CONTACT*

[julia.scorna@journalofculture.de](mailto:julia.scorna@journalofculture.de)

IMPORTANT *IMPORTANT !*

Tous les textes et œuvres d'art publiées ici sont  
la propriété intellectuelle de leurs auteurs  
et sont protégées par des documents allemands, français, européens et  
traités internationaux.

*All texts and artworks published herein are  
the intellectual property of their authors  
and are protected by German, French, European and  
international treaties.*



MICHAËL CAMELLINI

